

Full name:

Teacher name:

U6 A Level Maths STATISTICS & MECHANICS MOCK

April/May 2019

Time: 2 hours

Total Marks: 100

You must have: Mathematical Formulae and Statistical Tables, Calculator

Instructions

- Use black ink or ball-point pen.
- If pencil is used for diagrams/sketches/graphs it must be dark (HB or B).
- Fill in your name at the top of this page and the name of your teacher
- Answer all questions and ensure that your answers to parts of questions are clearly labelled.
- You should show sufficient working to make your methods clear. Answers without working may not gain full credit. Answers found from the calculator without working may not gain full credit.
- Answers should be given to three significant figures unless otherwise stated.

Information

- A booklet 'Mathematical Formulae and Statistical Tables' is provided.
- There are 10 questions. The total mark for this paper is 100.
- The marks for each question are shown in brackets
 - use this as a guide as to how much time to spend on each question.

Advice

- Read each question carefully before you start to answer it.
- Try to answer every question.
- Check your answers if you have time at the end.

Q1	Q2	Q3	Q4	Q5	Statistics	
5	7	11	13	14	50	
Q6	Q7	Q8	Q9	Q10	Mechanics	
6	8	8	13	15	50	Grade
				Total	100	

DO NOT WRITE IN THIS SPACE

A large rectangular area with rounded corners, containing 30 horizontal lines for writing. The lines are evenly spaced and extend across the width of the page.

DO NOT WRITE IN THIS SPACE

2. Tessa owns a small clothes shop in a seaside town. She records the weekly sales figures, $\pounds w$, and the average weekly temperature, t °C, for 8 weeks during the summer.

The product moment correlation coefficient for these data is -0.915 .

- (a) Stating your hypotheses clearly and using a 5% level of significance, test whether or not the correlation between sales figures and average weekly temperature is negative. (3)
- (b) Suggest a possible reason for this correlation. (1)

Tessa suggests that a linear regression model could be used to model these data.

- (c) State, giving a reason, whether or not the correlation coefficient is consistent with Tessa's suggestion. (1)
- (d) State, giving a reason, which variable would be the explanatory variable. (1)

Tessa calculated the linear regression equation as $w = 10755 - 171t$.

- (e) Give an interpretation of the gradient of this regression equation. (1)
- (7 marks)**

DO NOT WRITE IN THIS SPACE

DO NOT WRITE IN THIS SPACE

DO NOT WRITE IN THIS SPACE

DO NOT WRITE IN THIS SPACE

A large rectangular area with rounded corners, containing 30 horizontal lines for writing. The lines are evenly spaced and extend across the width of the page, leaving a margin on both sides. The entire page is enclosed in a thin black border.

3. In an experiment a group of children each repeatedly throw a dart at a target. For each child, the random variable H represents the number of times the dart hits the target in the first 10 throws.

Peta models H as $B(10, 0.1)$.

- (a) State two assumptions Peta needs to make to use her model. (2)
- (b) Using Peta's model, find $P(H \geq 4)$. (1)

For each child the random variable F represents the number of the throw on which the dart first hits the target.

Using Peta's assumptions about this experiment,

- (c) find $P(F = 5)$. (2)

Tom assumes that in this experiment no child will need more than 10 throws for the dart to hit the target for the first time. He models $P(F = n)$ as

$$P(F = n) = 0.01 + (n - 1) \times \alpha,$$

where α is a constant.

- (d) Find the value of α (4)
- (e) Using Tom's model, find $P(F = 5)$ (1)
- (f) Explain how Peta's and Tom's models differ in describing the probability that a dart hits the target in this experiment. (1)

(11 marks)

DO NOT WRITE IN THIS SPACE

DO NOT WRITE IN THIS SPACE

A large rectangular area with rounded corners, containing numerous horizontal lines for writing. The lines are evenly spaced and extend across the width of the page, leaving a narrow margin on the left and right sides. The entire page is enclosed in a thin black border.

DO NOT WRITE IN THIS SPACE

DO NOT WRITE IN THIS SPACE

A large rectangular area with rounded corners, containing 30 horizontal lines for writing. The lines are evenly spaced and extend across the width of the page, leaving a margin on both sides. The entire page is enclosed in a thin black border.

DO NOT WRITE IN THIS SPACE

A large rectangular area with rounded corners, containing 30 horizontal lines for writing. The lines are evenly spaced and extend across the width of the page.

DO NOT WRITE IN THIS SPACE

4. Charlie is studying the time it takes members of his company to travel to the office. He stands by the door to the office from 08 40 to 08 50 one morning and asks workers, as they arrive, how long their journey was.

(a) State the sampling method Charlie used. (1)

(b) State and briefly describe an alternative method of non-random sampling Charlie could have used to obtain a sample of 40 workers. (2)

Taruni decided to ask every member of the company the time, x minutes, it takes them to travel to the office.

(c) State the data selection process Taruni used. (1)

Taruni's results are summarised by the box plot and summary statistics below.

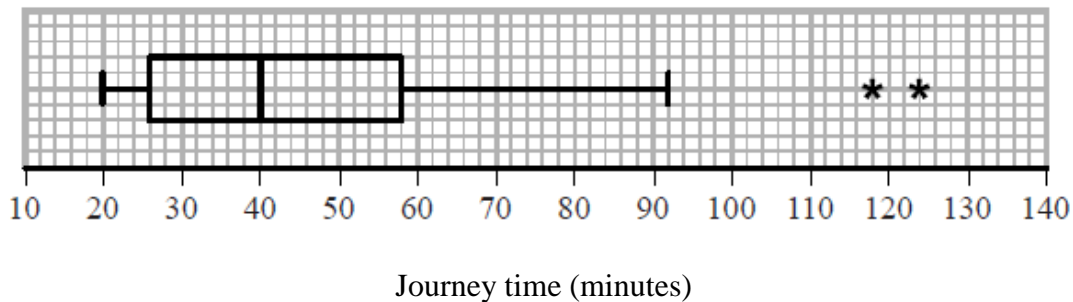

$$n = 95 \qquad \sum x = 4133 \qquad \sum x^2 = 202\,294$$

(d) Write down the interquartile range for these data. (1)

(e) Calculate the mean and the standard deviation for these data. (3)

(f) State, giving a reason, whether you would recommend using the mean and standard deviation or the median and interquartile range to describe these data. (2)

Rana and David both work for the company and have both moved house since Taruni collected her data. Rana's journey to work has changed from 75 minutes to 35 minutes and David's journey to work has changed from 60 minutes to 33 minutes.

Taruni drew her box plot again and only had to change two values.

(g) Explain which two values Taruni must have changed and whether each of these values has increased or decreased. (3)

(13 marks)

DO NOT WRITE IN THIS SPACE

A large rectangular area with rounded corners, containing 30 horizontal lines for writing. The lines are evenly spaced and extend across the width of the page.

DO NOT WRITE IN THIS SPACE

DO NOT WRITE IN THIS SPACE

DO NOT WRITE IN THIS SPACE

A large rectangular area with rounded corners, containing 30 horizontal lines for writing. The lines are evenly spaced and extend across the width of the page, leaving a margin on both sides. The area is intended for the main body of text.

DO NOT WRITE IN THIS SPACE

DO NOT WRITE IN THIS SPACE

A large rectangular area with rounded corners, containing 30 horizontal lines for writing. The lines are evenly spaced and extend across the width of the page, leaving a margin on both sides. The entire page is enclosed in a thin black border.

DO NOT WRITE IN THIS SPACE

DO NOT WRITE IN THIS SPACE

A large rectangular area with rounded corners, containing 30 horizontal lines for writing. The lines are evenly spaced and extend across the width of the page, leaving a margin on both sides. The entire page is enclosed in a thin black border.

DO NOT WRITE IN THIS SPACE

DO NOT WRITE IN THIS SPACE

A large rectangular area with rounded corners, containing 30 horizontal lines for writing. The lines are evenly spaced and extend across the width of the page, leaving a margin on both sides. The entire page is enclosed in a thin black border.

DO NOT WRITE IN THIS SPACE

DO NOT WRITE IN THIS SPACE

A large rectangular area with rounded corners, containing 30 horizontal lines for writing. The lines are evenly spaced and extend across the width of the page, leaving a margin on both sides. The entire page is enclosed in a thin black border.

DO NOT WRITE IN THIS SPACE

DO NOT WRITE IN THIS SPACE

A large rectangular area with rounded corners, containing 30 horizontal lines for writing. The lines are evenly spaced and extend across the width of the page, leaving a margin on both sides. The entire page is enclosed in a thin black border.

7.

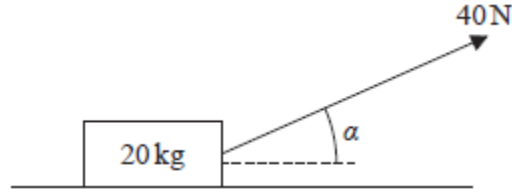

Figure 1

A wooden crate of mass 20 kg is pulled in a straight line along a rough horizontal floor using a handle attached to the crate.

The handle is inclined at an angle α to the floor, as shown in Figure 1, where $\tan \alpha = \frac{3}{4}$.

The tension in the handle is 40 N. The coefficient of friction between the crate and the floor is 0.14. The crate is modelled as a particle and the handle is modelled as a light rod.

Using the model,

- (a) find the acceleration of the crate.

(6)

The crate is now pushed along the same floor using the handle. The handle is again inclined at the same angle α to the floor, and the thrust in the handle is 40 N as shown in Figure 2 below.

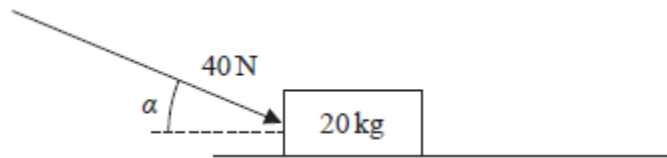

Figure 2

- (b) Explain briefly why the acceleration of the crate would now be less than the acceleration of the crate found in part (a).

(2)

(8 marks)

DO NOT WRITE IN THIS SPACE

DO NOT WRITE IN THIS SPACE

DO NOT WRITE IN THIS SPACE

DO NOT WRITE IN THIS SPACE

A large rectangular area with rounded corners, containing 30 horizontal lines for writing. The lines are evenly spaced and extend across the width of the page, leaving a margin on both sides. The entire page is enclosed in a thin black border.

DO NOT WRITE IN THIS SPACE

DO NOT WRITE IN THIS SPACE

A large rectangular area with rounded corners, containing 30 horizontal lines for writing. The lines are evenly spaced and extend across the width of the page, leaving a margin on both sides. The entire page is enclosed in a thin black border.

DO NOT WRITE IN THIS SPACE

A large rectangular area with rounded corners, containing 30 horizontal lines for writing. The lines are evenly spaced and extend across the width of the page.

DO NOT WRITE IN THIS SPACE

DO NOT WRITE IN THIS SPACE

DO NOT WRITE IN THIS SPACE

A large rectangular area with rounded corners, containing 30 horizontal lines for writing. The lines are evenly spaced and extend across the width of the page, leaving a margin on both sides. The entire page is enclosed in a thin black border.

9.

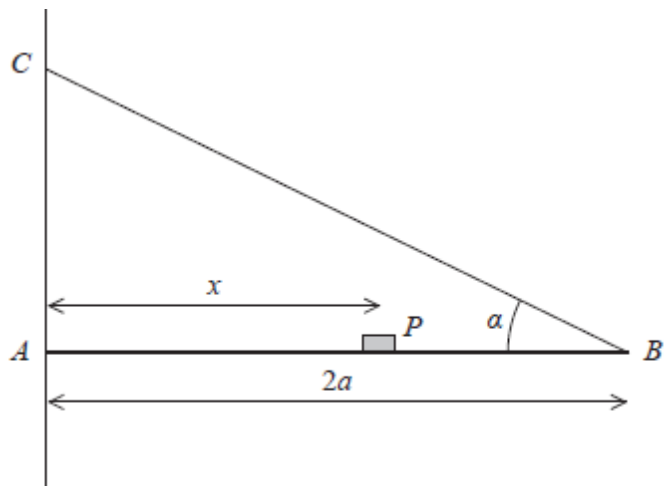

Figure 3

A plank, AB , of mass M and length $2a$, rests with its end A against a rough vertical wall. The plank is held in a horizontal position by a rope. One end of the rope is attached to the plank at B and the other end is attached to the wall at the point C , which is vertically above A .

A small block of mass $3M$ is placed on the plank at the point P , where $AP = x$.

The plank is in equilibrium in a vertical plane which is perpendicular to the wall.

The angle between the rope and the plank is α , where $\tan \alpha = \frac{3}{4}$, as shown in Figure 3.

The plank is modelled as a uniform rod, the block is modelled as a particle and the rope is modelled as a light inextensible string.

- (a) Using the model, show that the tension in the rope is $\frac{5Mg(3x+a)}{6a}$. (3)

The magnitude of the horizontal component of the force exerted on the plank at A by the wall is $2Mg$.

- (b) Find x in terms of a . (2)

The force exerted on the plank at A by the wall acts in a direction which makes an angle β with the horizontal.

- (c) Find the value of $\tan \beta$. (5)

The rope will break if the tension in it exceeds $5Mg$.

- (d) Explain how this will restrict the possible positions of P . You must justify your answer carefully. (3)

(13 marks)

DO NOT WRITE IN THIS SPACE

A large rectangular area with rounded corners, containing 30 horizontal lines for writing. The lines are evenly spaced and extend across the width of the page.

DO NOT WRITE IN THIS SPACE

DO NOT WRITE IN THIS SPACE

DO NOT WRITE IN THIS SPACE

A large rectangular area with rounded corners, containing 30 horizontal lines for writing. The lines are evenly spaced and extend across the width of the page, leaving a margin on both sides. The entire page is enclosed in a thin black border.

DO NOT WRITE IN THIS SPACE

DO NOT WRITE IN THIS SPACE

A large rectangular area with rounded corners, containing 30 horizontal lines for writing. The lines are evenly spaced and extend across the width of the page, leaving a narrow margin on the left and right sides. The entire page is enclosed in a thin black border.

10.

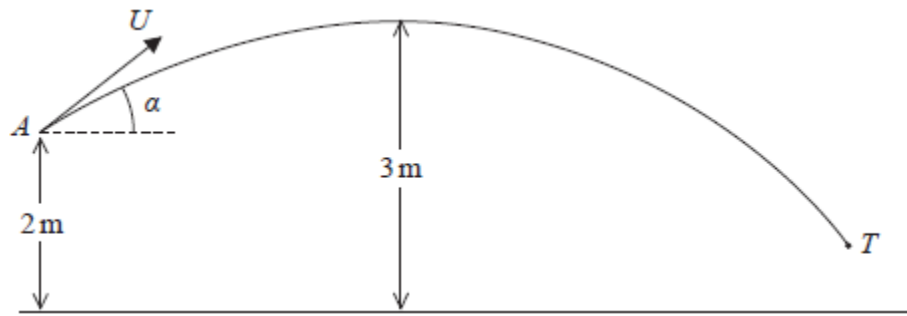

Figure 4

A boy throws a ball at a target. At the instant when the ball leaves the boy's hand at the point A , the ball is 2 m above horizontal ground and is moving with speed U at an angle α above the horizontal.

In the subsequent motion, the highest point reached by the ball is 3 m above the ground. The target is modelled as being the point T , as shown in Figure 4. The ball is modelled as a particle moving freely under gravity.

Using the model,

- (a) show that $U^2 = \frac{2g}{\sin^2 \alpha}$. (2)

The point T is at a horizontal distance of 20 m from A and is at a height of 0.75 m above the ground. The ball reaches T without hitting the ground.

- (b) Find the size of the angle α . (9)
- (c) State one limitation of the model that could affect your answer to part (b). (1)
- (d) Find the time taken for the ball to travel from A to T . (3)

(15 marks)

DO NOT WRITE IN THIS SPACE

DO NOT WRITE IN THIS SPACE

DO NOT WRITE IN THIS SPACE

A large rectangular area with rounded corners, containing 30 horizontal lines for writing. The lines are evenly spaced and extend across the width of the page.

DO NOT WRITE IN THIS SPACE

DO NOT WRITE IN THIS SPACE

A large rectangular area with rounded corners, containing 30 horizontal lines for writing. The lines are evenly spaced and extend across the width of the page.

DO NOT WRITE IN THIS SPACE

DO NOT WRITE IN THIS SPACE

DO NOT WRITE IN THIS SPACE

DO NOT WRITE IN THIS SPACE

DO NOT WRITE IN THIS SPACE

DO NOT WRITE IN THIS SPACE

DO NOT WRITE IN THIS SPACE